

Automatización Industrial

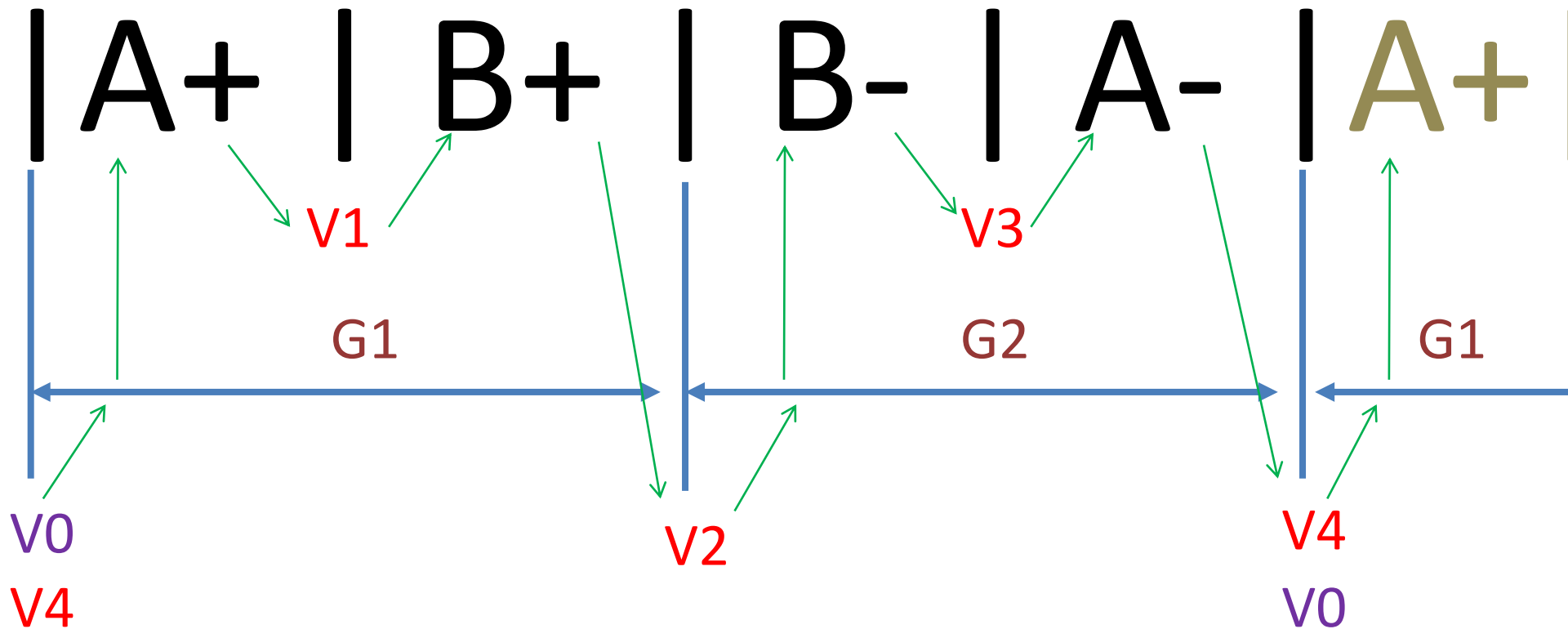

Secuencial Avanzadas en Sistema Neumáticos



Método en Cascada



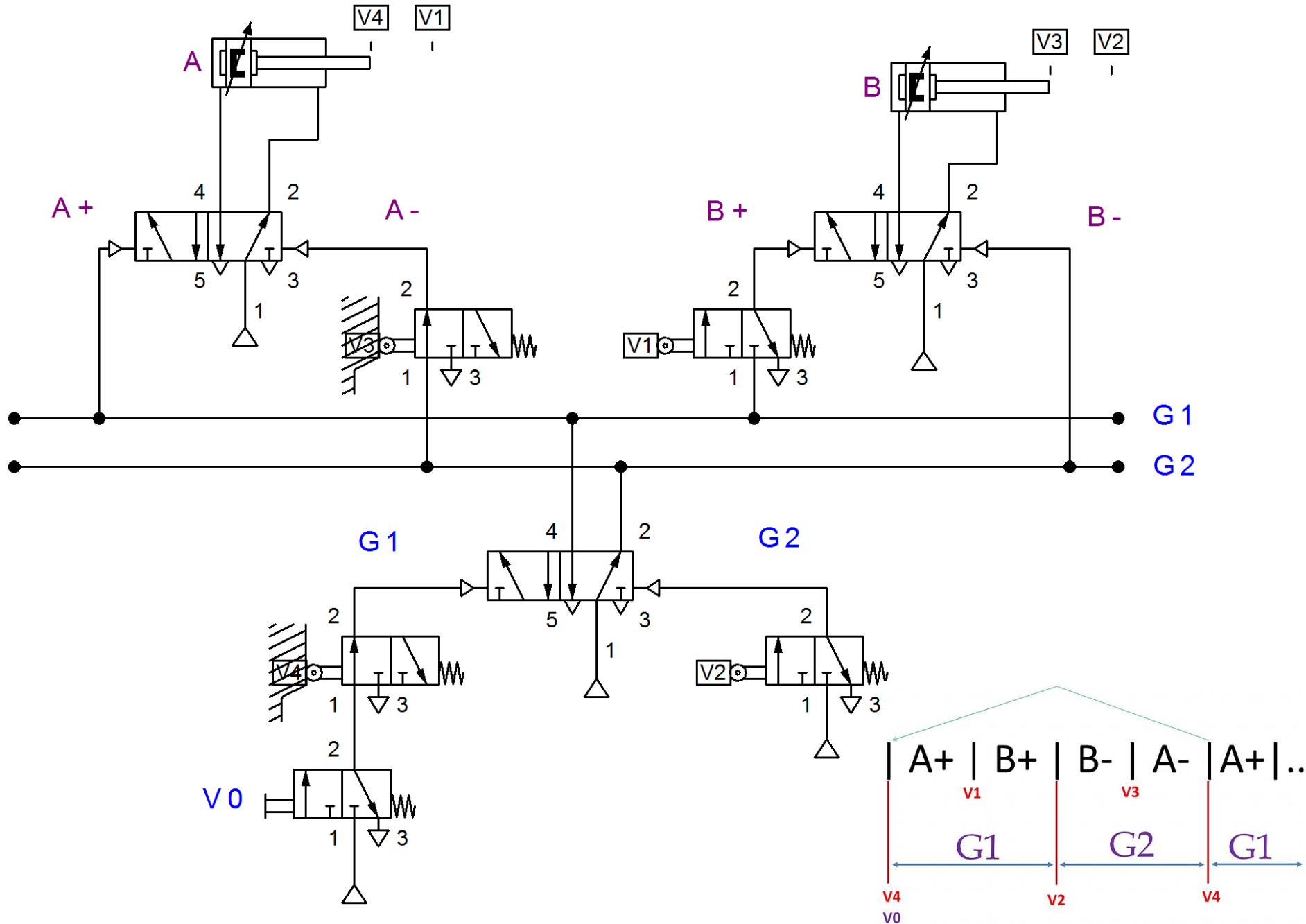

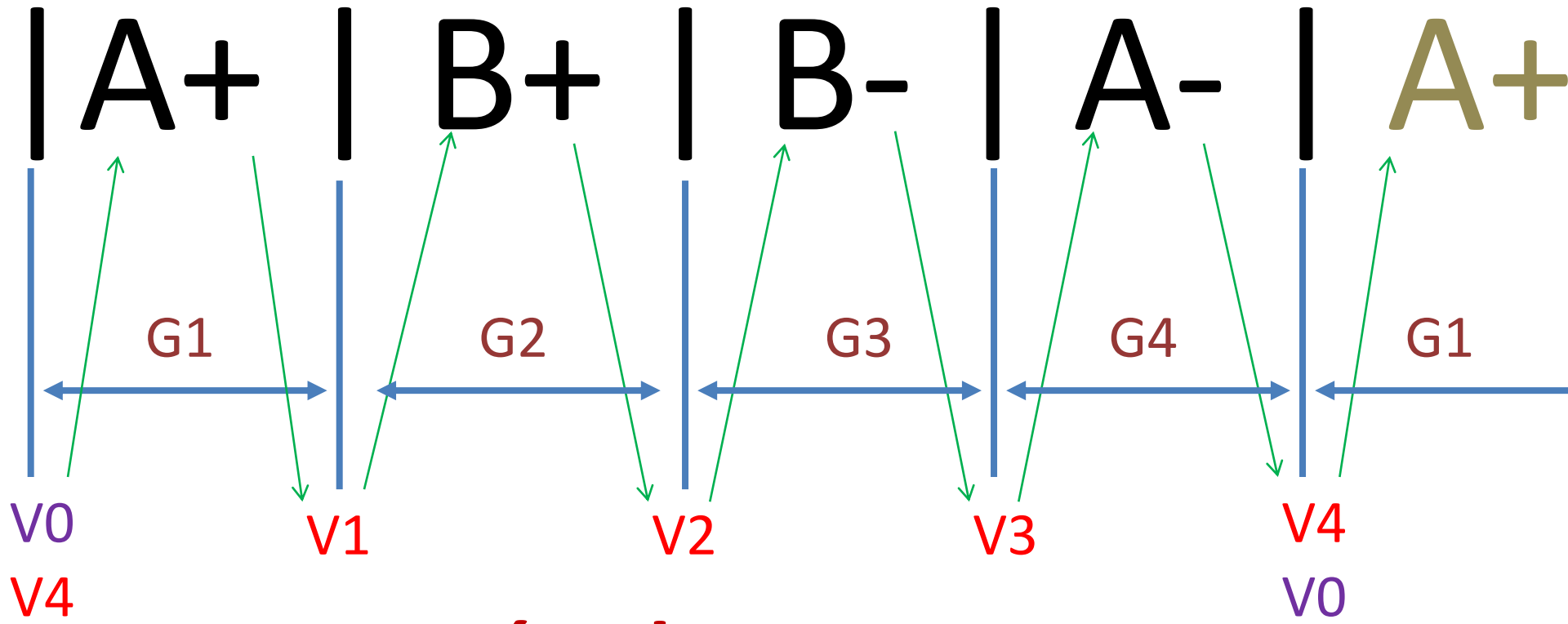

Método Paso a Paso



Metodo paso a paso

/ A+ / B+ / B- / A- /

/ G1 / G2 / G3 / G4 /

V0 V1 V2 V3 V4

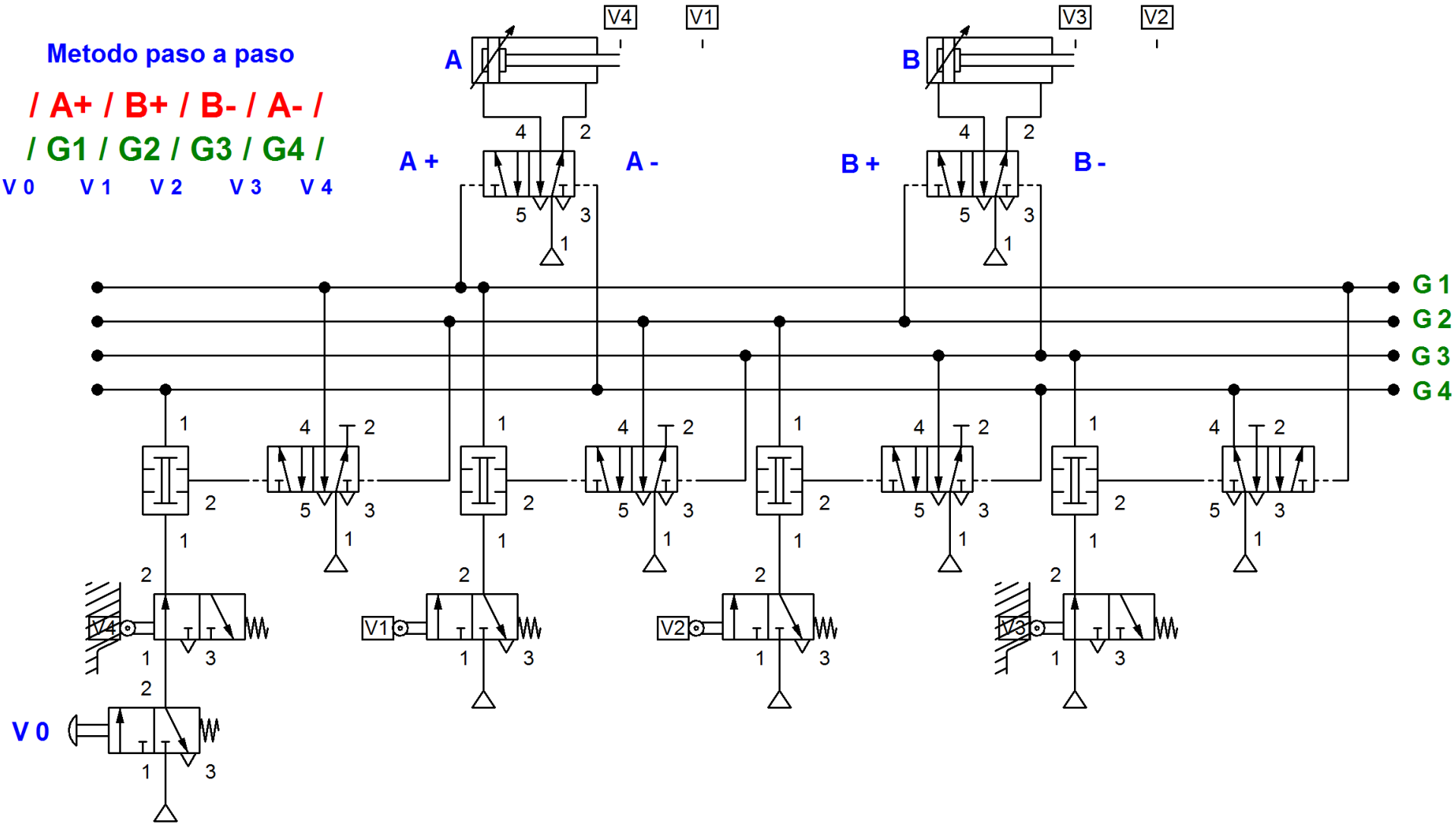

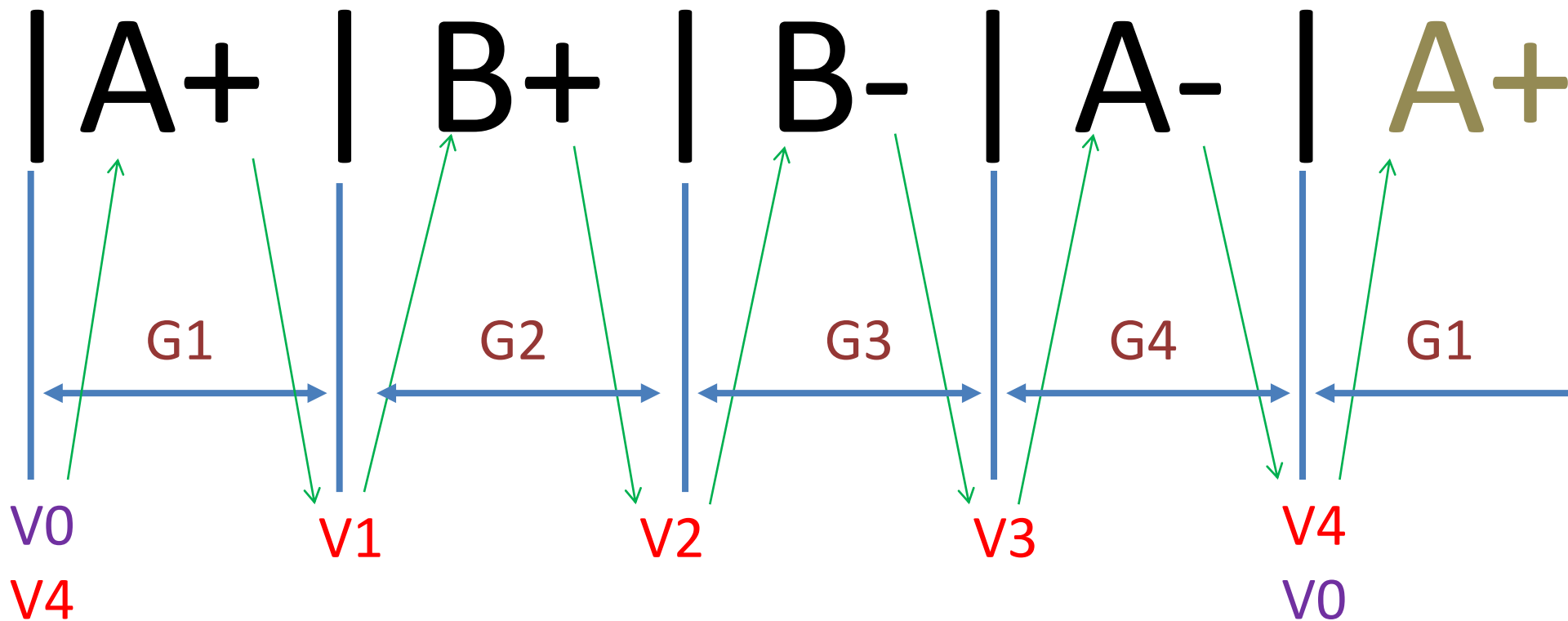

Módulos TAA -TAB



Modulos de secuencias

/ A+ / B+ / B- / A- /
V0 V1 V2 V3 V4

